

E

Electronic Indicators, Dial Indicators, Digital Probes, Digital Readouts

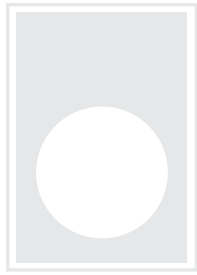

TABLE OF CONTENTS

Application	Series	Page
Electronic Indicators	900, 901, 903	E.2–E.3
Dial Indicators	450, 451, 458	E.4–E.5
Transducer Probes	971	E.6
Digital Display Box	981	E.7
Advanced Digital Readout Box	981	E.8–E.12
Measuring Applications Solutions		E.13–E.14

visit our searchable web site and
find Dyer's interactive
catalog, gaging solutions
by application and industry!

900 SERIES ELECTRONIC INDICATORS



900-301

Notable Features

- Resolution 0.0005"/0.01 mm
- Range 0–0.500"/12.7 mm
- Preset, zero, ± direction
Go/± NG functions
- Preset/recall absolute number.
Encoder maintains settings and readings for life of battery, (even when power is off)
- SPC output
- Battery Power 5000 hours
- Face rotates 330°
- Stem Ø 0.375", contacts 4-48 UNF



900-305

Notable Features

- Resolution 0.00005"/0.001 mm
- Range 0–0.500"/12.7 mm
- Preset, zero, ± direction
Go/± NG functions
- Preset/recall absolute number.
Encoder maintains settings and readings for life of battery, (even when power is off)
- SPC output
- Battery Power 5000 hours
- Face rotates 330°
- Stem Ø 0.375", contacts 4-48 UNF



900-114

Notable Features

- Resolution 0.0001"/0.001 mm
- Range 0–0.500"/12.7 mm
- Holds min value/tolerance
- Preset up to 3 values
- Analog bar
- Preset, zero, ± direction
Go/± NG functions
- Preset/recall absolute number.
Encoder maintains settings and readings for life of battery, (even when power is off)
- SPC output
- Battery Power 5000 hours
- Face rotates 330°
- Stem Ø 0.375", contacts 4-48 UNF



900-315

Notable Features

- Resolution 0.0005"/0.01mm
- Range 0–0.500"/0-12.7mm
- Zero, ± direction
- No preset to absolute
- SPC output
- Battery power 20,000 hours
- Low Cost
- Face rotates 330°
- Stem Ø 0.375", contacts 4-48 UNF



900-200

Notable Features

- Any ratio calculation can be programmed
- Resolution adjustable from 0.000010"–0.050" (0.002 mm–1 mm)
- Range 0–0.500"/12.7 mm
- Preset, zero, ± direction Go/± NG functions
- Preset/recall absolute number.
Encoder maintains settings and readings for life of battery, (even when power is off)
- SPC output
- Battery Power 5000 hours
- Face rotates 330°
- Stem Ø 8 mm, contacts 2.5 mm



900-325

Notable Features

- Resolution 0.000050"/0.0001mm
- Range 0–0.500"/0-12.7mm
- Zero, ± direction
- No preset to absolute
- SPC output
- Battery power 20,000 hours
- Low Cost
- Face rotates 330°
- Stem Ø 0.375", contacts 4-48 UNF



901, 903 SERIES ELECTRONIC INDICATORS

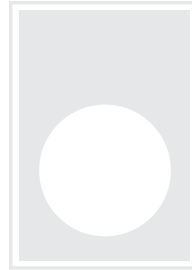

901-100

Notable Features

- Resolution 0.000050"/0.001 mm
- Range 0–1.0"/25 mm
- Zero, preset/recall absolute number
- Battery Power, face rotates 270°
- RS232, SPC output, bi-directional
- Stem Ø 0.375", contacts 4-48 UNF



901-101

Notable Features

- Resolution 0.0005"/0.01 mm
- Range 0–1.0"/25 mm
- Zero, preset/recall absolute number
- Battery Power, face rotates 270°
- RS232, SPC output, bi-directional
- Stem Ø 0.375", contacts 4-48 UNF



903-115

Notable Features

- Range ± 0.040 "/1 mm
- Fan display
- Battery Power
- Stem Ø 0.375", contacts 4-48 UNF
- Switchable resolution
0.00020"/0.0005 mm
0.00050"/0.001 mm
0.0001"/0.001 mm
0.0005"/0.005 mm



903-118

Notable Features

- Resolution 0.000050", 0.00020", 0.00010"/0.001 mm, 0.0005 mm, 0.0002 mm
- Range
 ± 0.0015 "/0.030 mm
 ± 0.0006 "/0.015 mm
 ± 0.0003 "/0.006 mm
- Preset/recall absolute number
- SPC output
- Battery Power
- Stem Ø 0.375", contacts 4-48 UNF



903-120

Remote Indicator

Notable Features

- Range ± 0.040 "/1 mm
- Fan display
- Battery Power
- Switchable resolution
0.00020"/0.0005 mm
0.00050"/0.001 mm
0.0001"/0.001 mm
0.0005"/0.005 mm



901-201

Notable Features

- Resolution 0.00050"/0.01 mm
- Range 0-1"/0-25.4 mm
- Button Function: ON/OFF, ZERO, in/mm
- Auto power off
- SPC output/USB
- CR2032 Battery, Battery life > 1 year
- Stem 0.375", contacts 4-48 UNF



450, 451, 458 SERIES DIAL INDICATORS

451-001 Inch

Notable Features

- Graduation 0.000050"
- Range 0.004" (± 0.002 ")
- Dial face 20-0-20
- Range per revolution ± 0.002 "
- Stem \varnothing 8 mm, spindle lapped
- Fine adjustment at top of case



451-011 Metric

Notable Features

- Graduation 0.001 mm
- Range 0.1 mm (± 0.050 mm)
- Dial face 50-0-50
- Range per revolution ± 0.050 mm
- Stem \varnothing 8 mm, spindle lapped
- Fine adjustment at top of case



450-000 Inch

Notable Features

- Graduation 0.000050"
- Range 0.004" (± 0.002 ")
- Dial face 20-0-20
- Range per revolution ± 0.002 "
- Stem \varnothing 8 mm, spindle lapped



458-003 Metric

Notable Features

- Resolution 0.002 mm
- Range 1 mm
- Dial face 0-100-0
- Range per revolution 0.2 mm
- Stem \varnothing 8 mm, spindle lapped

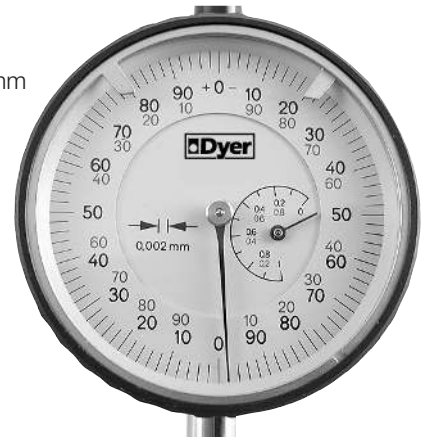

458-001 Inch

Notable Features

- Graduation 0.0001"
- Range 0.200"
- Dial face 0-5-0
- Range per revolution 0.010"
- Stem \varnothing 3/8", spindle lapped



458-002 Inch

Notable Features

- Graduation 0.0005"
- Range 0.500"
- Dial face 0-25-0
- Range per revolution 0.010"
- Stem \varnothing 3/8", spindle lapped



450, 451, 458 SERIES DIAL INDICATORS

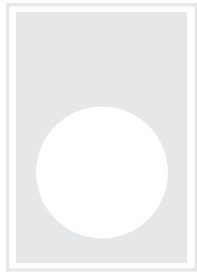

450-001 Inch

Notable Features

- Resolution 0.0001"
- Range 0.040"
- Dial face 0-10
- Range per revolution 0.010"
- Stem Ø 8 mm, spindle lapped



450-002 Inch

Notable Features

- Resolution 0.0005"
- Range 0.500"
- Dial face 0-50
- Range per revolution 0.050"
- Stem Ø 8 mm, spindle lapped



458-004 Metric

Notable Features

- Resolution 0.01 mm
- Range 10 mm
- Dial face 0-50-0
- Range per revolution 1.0 mm
- Stem Ø 8 mm, spindle lapped



450-012 Metric

Notable Features

- Resolution 0.01 mm
- Range 10 mm
- Dial face 0-100
- Range per revolution 1.0 mm
- Stem Ø 8 mm, spindle lapped

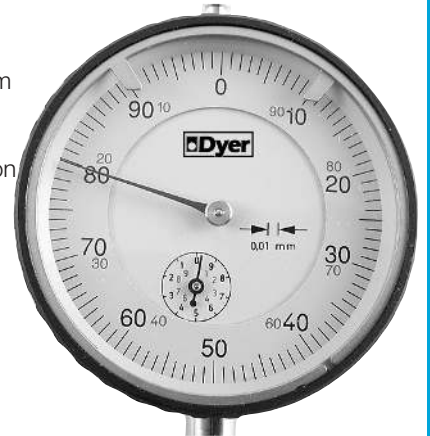

458-015 Inch

Notable Features

- Resolution 0.001"
- Range 0.080"
- Dial face 40-0-40
- Stem Ø 8 mm, spindle lapped



458-020 Metric

Notable Features

- Resolution 0.010 mm
- Range 0.80 mm
- Dial face 40-0-40
- Stem Ø 8 mm, spindle lapped

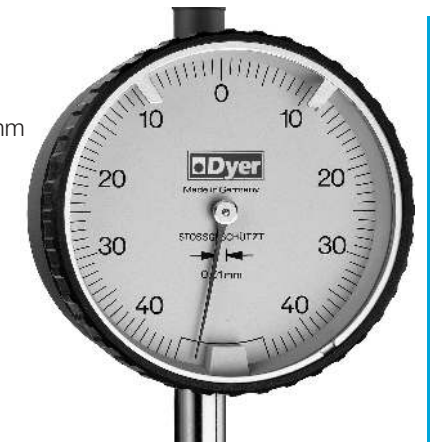

971 SERIES TRANSDUCER PROBES

971-100 STANDARD Digital Probe Features

- The 971-100 transducer probe has a measuring range of 0.089"-2 (2mm)
- Accuracy of ± 0.000004 "-2 (0.0001mm)
- Built for the shop floor. Robust design.
- High thermal stability translates to high accuracies even when used 24-7.

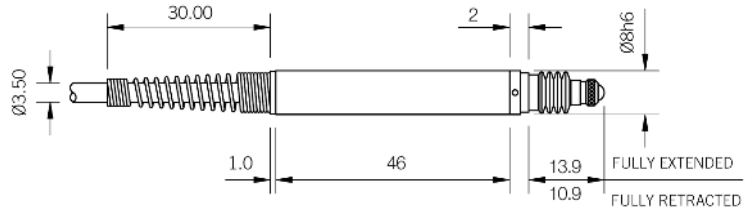

971-100 Probe

Model	971-100
Measuring Range	0.080"-2 (2mm)
Accuracy	± 0.000004 "-2 (± 0.0001 mm)
Temperature Range	32° to 140° F (0° to 60° C)
Stem Diameter	8mm
Contact Tip	3mm diameter carbide ball, with M2.5 thread
Cable Length	6.55 feet (2M) – Axial Cable Outlet

971-200 EXTENDED Range Digital Probe Features

- The 971-200 transducer probe has a large measuring range of 0.472"-2 (12mm)
- Accuracy of ± 0.000040 "-2 (0.001mm) applies for the entire travel of the measuring probe. Nothing is lost as the travel increases.
- Built for the shop floor. Robust design.
- High thermal stability translates to high accuracies even when used 24-7.

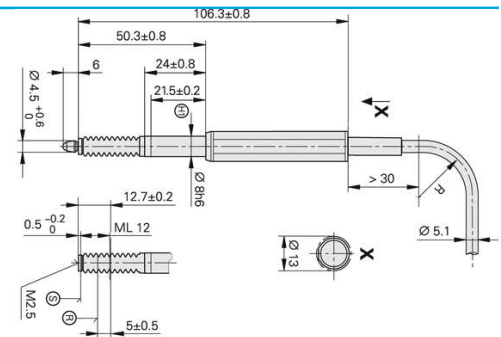

971-200 Probe

Model	971-200
Measuring Range	0.472"-2 (12mm)
Accuracy	± 0.000040 "-2 (± 0.001 mm)
Temperature Range	50° to 104° F (10° to 40° C)
Stem Diameter	8mm
Contact Tip	3mm diameter carbide ball, with M2.5 thread
Cable Length	5 feet (1.5M) – Axial Cable Outlet

971-300 REMOTE Digital Probe Features

- The 971-300 remote transducer probe has a measuring range of 0.080"-2 (2mm)
- Accuracy of ± 0.000040 "-2 (0.001mm)
- Built for the shop floor. Robust design.
- High thermal stability translates to high accuracies even when used 24-7.

Model	971-300
Measuring Range	0.080"-2 (2mm)
Accuracy	± 0.000040 "-2 (± 0.001 mm)
Temperature Range	50° to 130° F (10° to 55° C)
Stem Diameter	0.375"-2
Contact Tip	hardened radius tip with 4-48 thread
Cable Length	4 feet (1.2M) – Axial Cable Outlet

903-120 Indicator
Offered separately



971-300 Remote Probe

981 SERIES DISPLAY BOX

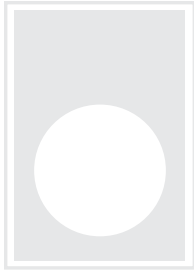

981-200 Digital Readout for one axis measurements

Notable Features

- The 981-200 has selectable resolution as low as 0.000020" (0.0005mm)
- Can store up to 1000 measured values
- Minimum/Maximum value storage
- Can calculate mean value and standard deviations
- Creates histograms and control charts
- Various other statistical functions



981-200 Box shown
with motorized control device for transducer probe

Specifications	
Data Interface	Two serial interfaces: RS-232-C/V.24 110 to 115 200 baud USB Type B (UART)
Operating temperature	0°C–50°C (32°F–122°F)
Storage temperature	-40°C–85°C (-40°F–185°F)
Relative air humidity	Annual mean: < 75% In exceptional cases: <90%
Protection (IEC 60529)	IP 40 rear panel; IP 54 front panel
Weight	Approximately 2.5 kg (5.5 lb)
Housing	Benchtop Design, cast metal housing
Housing dimensions	Width 211 mm Height 112 mm (including feet) Depth 251 mm (including connector)



981-200 Box shown
with various transducer stands

981 SERIES DIGITAL READOUTS VISUAL FEEDBACK

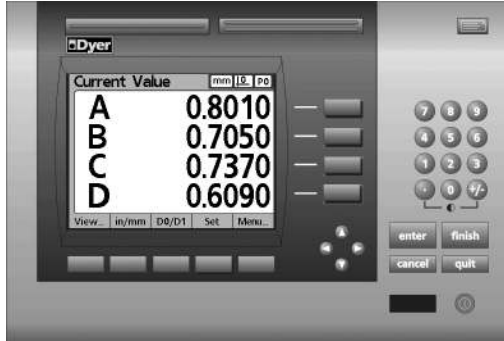

Overview

- Up to 8 Encoder or LVDT inputs.
- LVDT Signal Conditioning.
- Color LCD Display.
- Custom Formula.
- Data Charts & Graphs.
- SPC Database & Calculations.
- Assignable dimension tolerances.

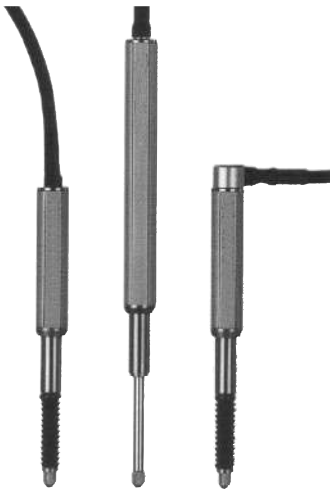

Input/Output

- Up to eight encoder or full bridge LVDTs.
- Provides LVDT signal conditioning.
- Encoder inputs; Heidenhain, Mitutoyo, Nikon.
- LVDT inputs; Solartron, Marposs, Tesa.
- Display up to 16 dimensions.
- Parallel/serial port for printing/communications.
- Two programmable relay outputs.

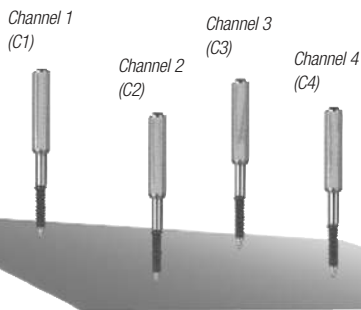

Advanced Calculations

- Create custom formulas to track critical dimensions.
- Assign formulas to determine max and min dimensions.
- Unique "trip function" automates data entry.
- Determine run-out of a rotating shaft.
- Encoders can be combined algebraically to calculate thickness, flatness and volume.

$$F = \max (C1, C2, C3, \dots Cn) - \min (C1, C2, C3, \dots Cn)$$

DIGITAL READOUTS 981 SERIES

A GAGING BREAKTHROUGH FOR THE FACTORY FLOOR

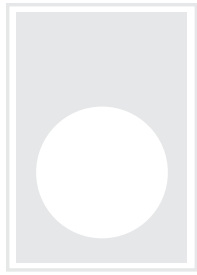

This DRO is a multi-axis metrology display that accepts up to eight discrete inputs. It features intuitive visual displays, helpful audio cues and user-defined formulas. It also reports dynamic Min/Max measurements, provides SPC analysis from an integrated database and includes connectivity to PCs and other peripherals.

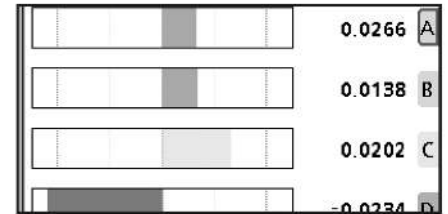

Visual feedback

A highly visible, intuitive and familiar interface with standard color cues. Instantly informs operators of pass/fail performance details for critical part dimensions.

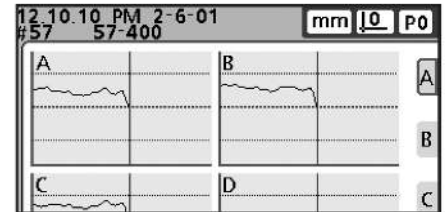

Integrated SPC database

Store, retrieve and manage enormous amounts of measurement data on the shop floor. Check quality control of each gage. Share information locally and globally.

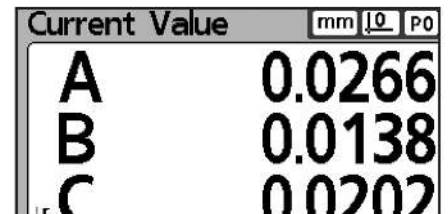

Formulas

Up to 16 output channels apply mathematical formulas to measurement data for on-the-spot part analysis.

981 Series Specifications		Inputs
LCD	6" color	4 and 8-axis input available External connections: Footswitch Remote keypad Touch probe RS-232C serial port Parallel port – 16 pin Outputs Parallel port – 16 pin / Data output to USB stick
Display digit size	.45"	
Resolution down to	.000004" or .0001 mm	
Operating temperature	0°C–45°C	
Enclosure (W × H × D)	11.5" × 7.5" × 2.75"	
Base (W × H × D)	10" × 2" × 7.5"	
Enclosure weight	5.4 lbs	
Base weight	6.2 lbs	
Input voltage range	85 VAC–264 VAC	
Input frequency	43 Hz–63 Hz	

Ordering Information

Analog	Order No.
4 Gage Input	981-004
8 Gage Inputs	981-008

Digital	Order No.
up to 16 Gage Inputs	981-000

Standard boxes configured for Heidenhain probes.

981 SERIES DIGITAL READOUTS

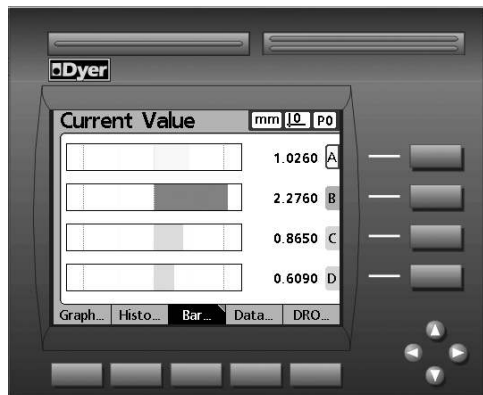

View as Column Gages

Color-coded vertical or horizontal bar graphs
User selectable high/low tolerance limits
User-settable audio warning limits
Display one, four or eight bar graphs for quick pass/fail notification

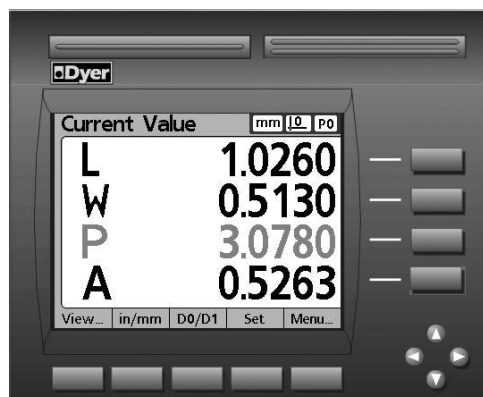

Easy to view DRO

Customizable display to reflect part dimension
Large, easy to read numerical display
Color coded pass/fail with audio alert
Inch/mm toggle

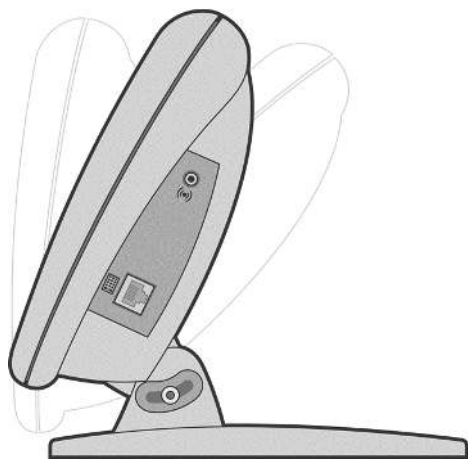

Digital Readouts

- Ergonomic design
- Intuitive user interface
- Familiar, powerful measurement tools
- Single- and multi-sensor environments

981 SERIES DIGITAL READOUTS DATA VIEWING AND COLLECTION

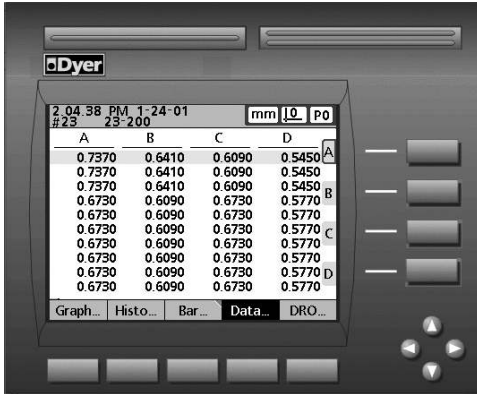
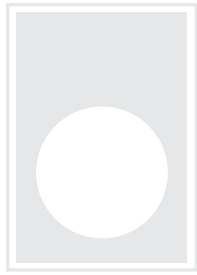

Data Output

- RS232 interface to computer.
- Customizable color report print-outs using standard HP ink jet printers.
- 2 switching outputs.
- Output single record measurement or an entire data report.

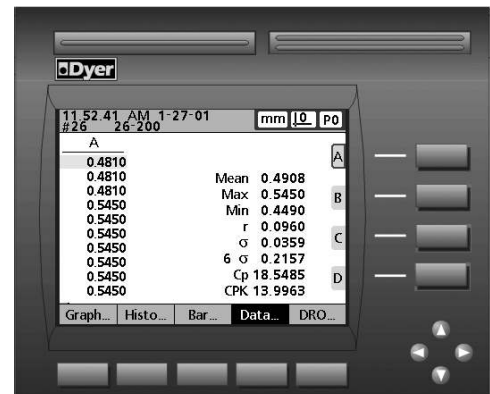

Historical Data Views

- Display single or multiple dimensions.
- Display SPC statistics.
- Each dimension is time and date stamped.

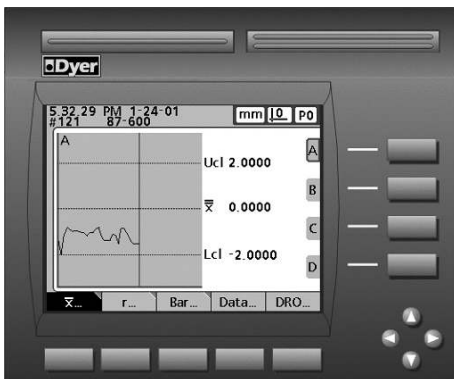

SPC Charts

X-Bar and range charts.
Assign subgroup size.
Set visual warning limits.
Display charts for one, four or eight dimensions on screen.

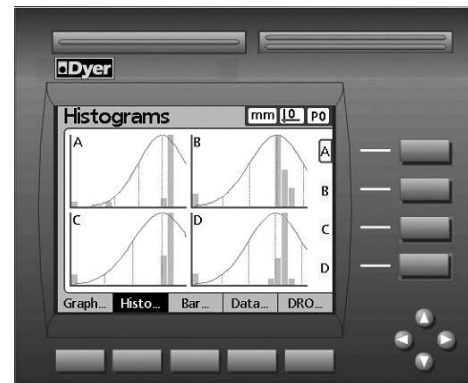

SPC Charts

- Display process capability charts.
- Display charts for one, four or eight dimensions on screen.

981 SERIES ACCESSORIES

Description	Order No.
2-function footswitch w/ 8' cable	981-501
8-function remote keypad w/ 15' cable	981-502
8-function remote keypad w/ 25' cable	981-503
Dot-matrix 40-column printer w/ RS-232 cables	981-504
Dot-matrix 80-column printer w/ RS-232 cables	981-505
Printer paper for 40-column printer	981-506
9-pin serial cable	981-507
Serial printer cable	981-508
QC tray stand	981-509
Swivel arm-mounting bracket for QC tray stand	981-510
QC arm-mounting bracket adapter	981-511
Arm-mounting bracket	981-512
Fowler's 16-bit Software Wedge	981-513
GC-100 instruction manual	981-514



Dot-matrix printers

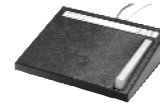

Two-function footswitch



Eight-function remote keypad

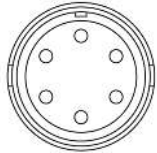

MLG Mitytoyo linear gage		Order No.
6-pin round connector for Mitutoyo linear gages	1-axis	981-601
	4-axis	981-602
	8-axis	981-603

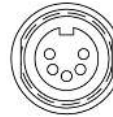

SL-F Solartron		Order No.
Full-bridge LVDT probe interface	1-axis	981-616
	4-axis	981-617
	8-axis	981-618



MP-F Marposh		Order No.
Full-bridge LVDT probe interface	1-axis	981-604
	4-axis	981-605
	8-axis	981-606

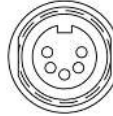

SL-H Solartron		Order No.
Half-bridge HBT probe interface	1-axis	981-619
	4-axis	981-620
	8-axis	981-621



MP-H Marposh		Order No.
Half-bridge HBT probe interface	1-axis	981-607
	4-axis	981-608
	8-axis	981-609

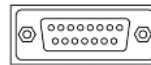

SP Heidenhain Spectro		Order No.
15-pin D-sub female connector for 1vp-p Spectro gages	1-axis	n/a
	2-axis	n/c
	3-axis	n/c

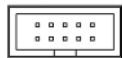

MSR Mitutoyo		Order No.
10-pin rectangular connector for Mitutoyo serial gages	1-axis	981-610
	4-axis	981-611
	8-axis	981-612



TS-F Tesa		Order No.
Full-bridge LVDT probe interface	1-axis	981-622
	4-axis	981-623
	8-axis	981-624

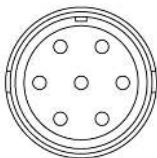

NL Nikon linear scales or Digi-Micro		Order No.
7-pin round female connector; .001mm, .002mm, .004mm, .005mm resolutions	1-axis	981-613
	4-axis	981-614
	8-axis	981-615

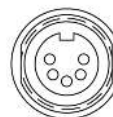

TS-H Tesa		Order No.
Half-bridge HBT probe interface	1-axis	981-625
	4-axis	981-626
	8-axis	981-627

Note: Digi-Micro requires 11B11219 cable

n/c - no charge
n/a - not available

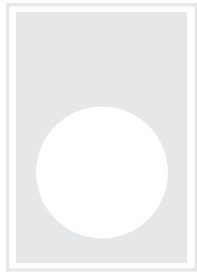

Build Your Own Gage

Using Dyer Digital Probes, linear encoders and digital readout, you can easily build your own tabletop gage.

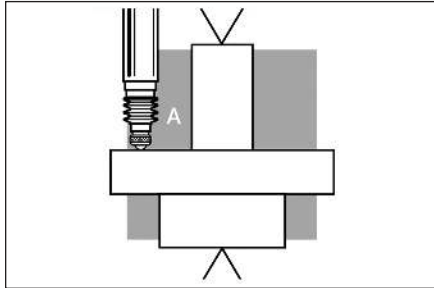

TIR max - min measuring

Digital Readout

This is Dyer's most advanced, yet easy-to-use, Digital Readout. "Auto custom" display guides the operator through the setup or Dyer will set up a system for you.

Network Systems

Easily sets up for SPC Data Collection.

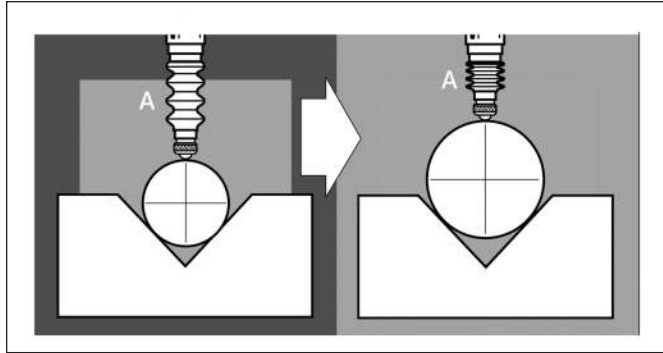

Scaling factor measuring

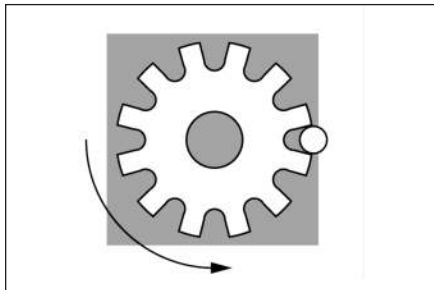

TIR of gears

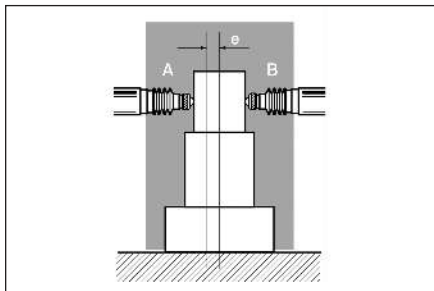

Scaling mode

$$e = A - B$$

$$\frac{2}{\text{Max} - \text{min}}$$

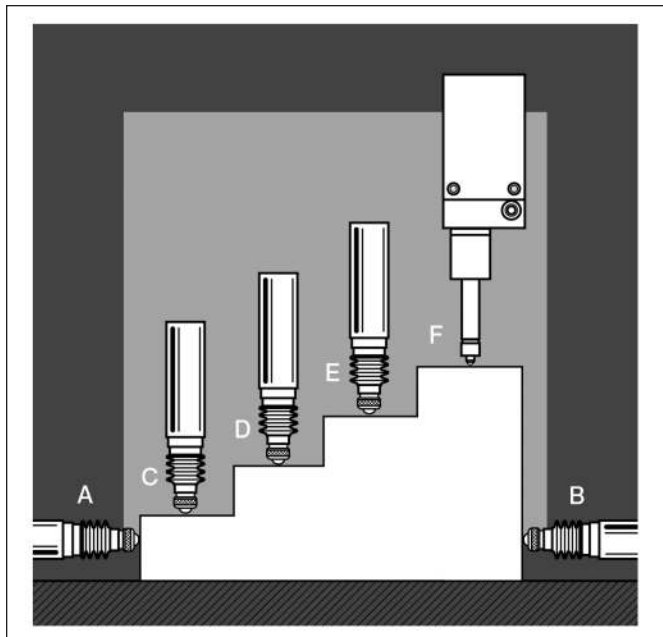

Global pass/fail measuring of up to 30 scan channels (up to 30 probes). Each channel can be either an individual probe A + B or A - B and have its own set of limit and preset values.

124, 125, 971, 981 SERIES MEASURING APPLICATION SOLUTIONS

Build Your Own System

Dyer's Digital Probes and Readouts along with our component fixturing will make the high accuracy measurements you require. Just contact Dyer's office with your measuring applications.

Absolute Measurements

The Dyer Digital Probe is an absolute measuring device, which means when you switch it on it returns to the correct output regardless of movements during the off periods.

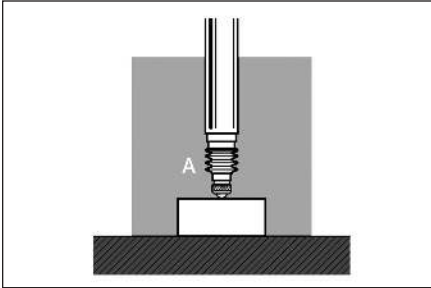

Height or gage block measuring

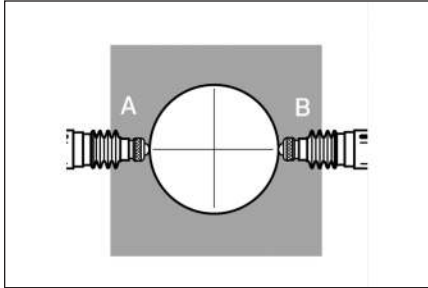

Diameter measuring independent of eccentricity

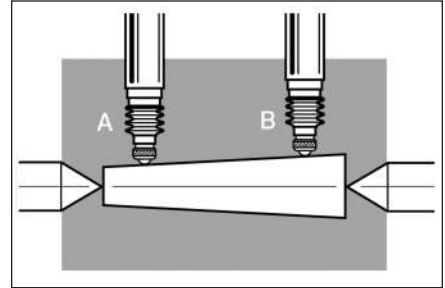

Taper measuring independent of component dimensions

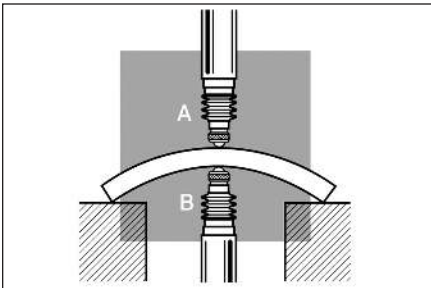

Thickness measuring independent of component shape or location

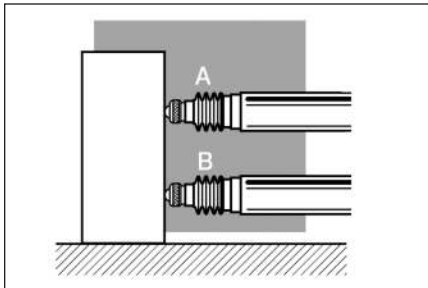

Squareness measuring independent of position

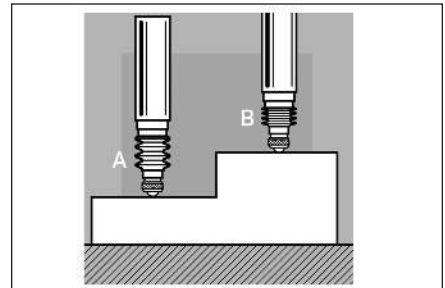

Step height measuring

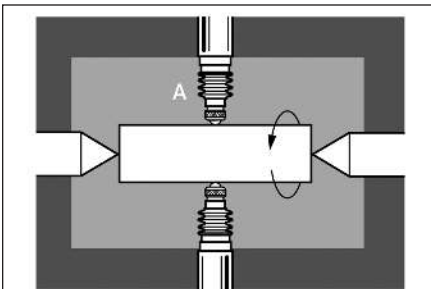

Max - min or max + min

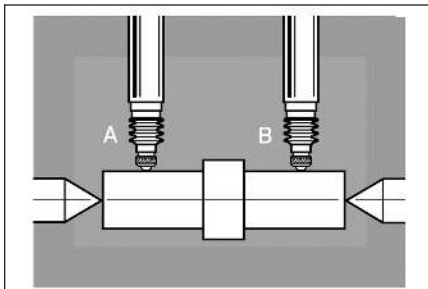

Measuring alignment of two shafts

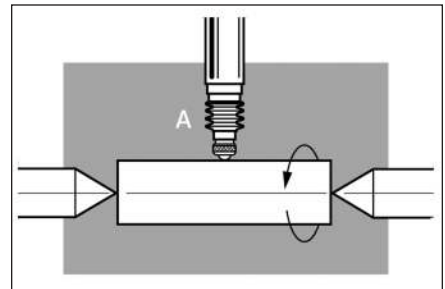

Out-of-roundness measuring independent of eccentricity with sum of measurement